

MINIMILL

Nut- und Formzirkularfräsen

groove milling by circular interpolation

Typ Z616 / Z616.X

Nutfräsen allgemein

for groove milling general use

D min. 16 mm
t max. = 3.5

D min. 16 mm
t max. = 3.5

Z616 geradverzahnt / spur-toothed

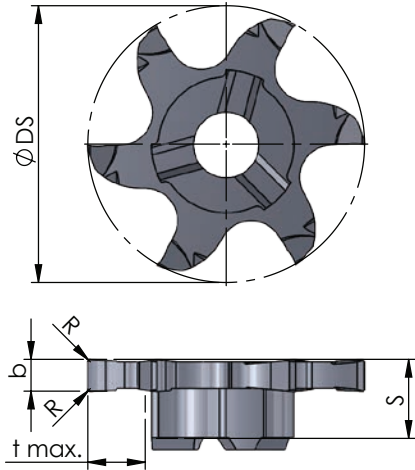

Z616.X kreuzverzahnt / staggered-toothed

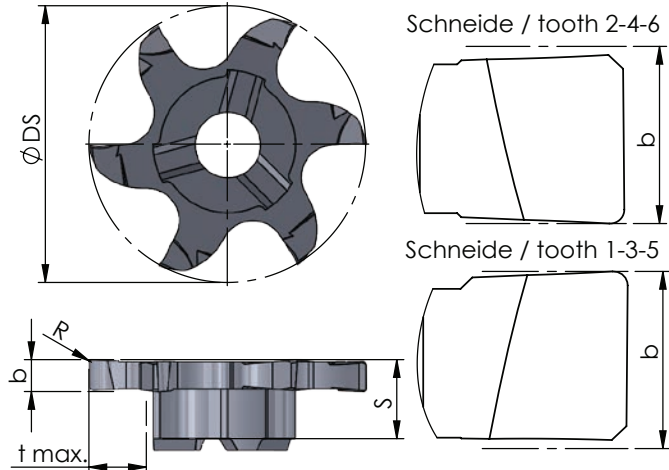

Abmessungen in mm

dimensions in mm

Bestellnummer part number	D min.	S	R	Ø DS	b +0.02	t max.	Zähnezahl number of teeth	Material			für Fräterschaft for milling shank
								K10F	AL41F	P18C	
Z616.X150.02	16	4.5	0.2	15.7	1.5	3.5	6	●			ZH14...
Z616.0200.02	16	4.5	0.2	15.7	2.0	3.5	6		●		
Z616.X200.02	16	4.5	0.2	15.7	2.0	3.5	6		●		
Z616.0250.02	16	4.5	0.2	15.7	2.5	3.5	6		●		
Z616.X250.02	16	4.5	0.2	15.7	2.5	3.5	6		●		

Weitere HM Sorten können Sie in der Sortenübersicht im Kapitel "Technische Hinweise" und der Preisliste finden.

Bestellbeispiel:
für Sorte AL41F:
Z616.X150.02/AL41F

More carbide grades you can find in the grades summary in the chapter "technical instructions" and in the price list.

order-example:
grade AL41F:
Z616.X150.02/AL41F