

# CYLINDRICAL ANVIL TUBE MICROMETERS

Unit: mm



**3261-25A**

- Measure wall thickness of tubes
- Graduation 0.01mm
- Ratchet stop
- Carbide spindle tip
- Supplied with setting standards (except 0-25mm)

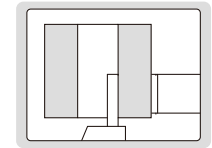
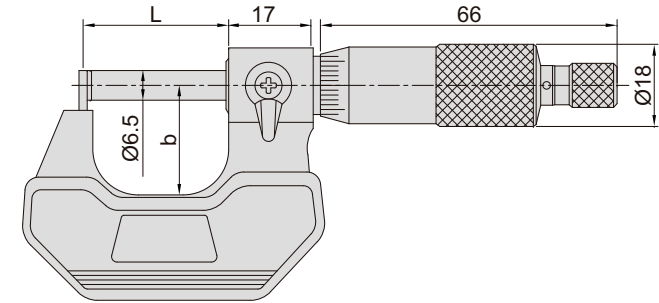

(mm)

Code	Range	Type	Accuracy	L	b
<b>3261-25A</b>	0-25mm	A	6µm	36	25
<b>3261-50A</b>	25-50mm	A	6µm	61	32
<b>3261-25BA</b>	0-25mm	B	6µm	36	25
<b>3261-50BA</b>	25-50mm	B	6µm	61	32
<b>3261-25CA</b>	0-25mm	C	6µm	36	25
<b>3261-50CA</b>	25-50mm	C	6µm	61	32
<b>3261-25DA</b>	0-25mm	D	6µm	36	25
<b>3261-50DA</b>	25-50mm	D	6µm	61	32
<b>3261-25EA</b>	0-25mm	E	6µm	36	25
<b>3261-50EA</b>	25-50mm	E	6µm	61	32
<b>3261-25FA</b>	0-25mm	F	6µm	36	25
<b>3261-50FA</b>	25-50mm	F	6µm	61	32

