

DIGITAL INSIDE GROOVE CALIPERS

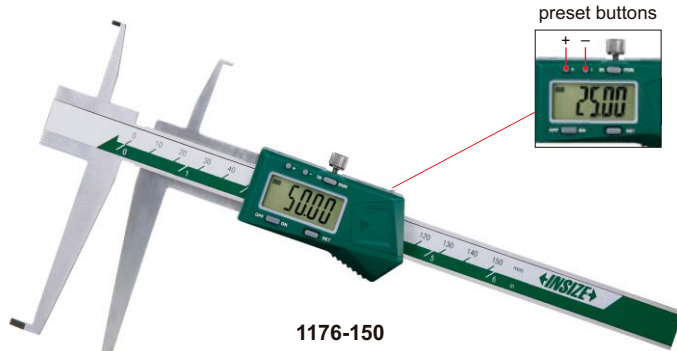

preset buttons

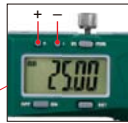

1176-150



1176-150P

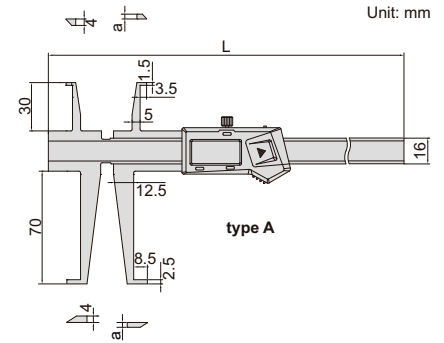

type A

Unit: mm

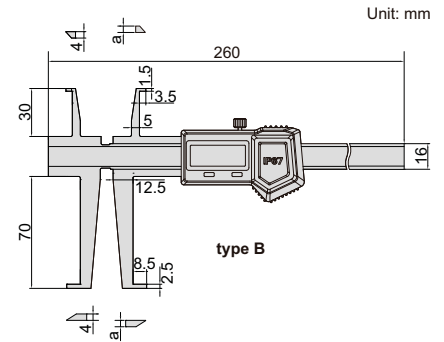

type B

Unit: mm

- Measure diameter of grooves inside bores
- Resolution: 0.01mm/0.0005"
- Buttons:
 - on/off, set, mm/inch, preset (+, -) (type A)
 - on/off, zero, mm/inch, ABS/REL, hold (type B)
- Battery CR2032
- Made of stainless steel
- Optional accessory: depth stop (code 6143), data output cable (code 7315-, 7302-, 7305-, for type A calipers without built-in wireless)

depth stop 6143 (optional)



sizes to be measured (use upper jaws)

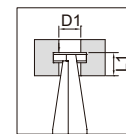

sizes to be measured (use lower jaws)

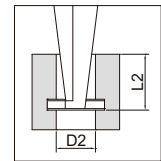

No dust/waterproof (data output, automatic power off, preset)

(mm)

Code	Range of upper jaw	Range of lower jaw	Type	Accuracy	L	a	Wireless
1176-150	9-150mm/0.35-6"	17-150mm/0.70-6"	A	±0.04mm	260	3	no
1176-150WL							built-in wireless
1176-200	9-200mm/0.35-8"	17-200mm/0.70-8"	A	±0.05mm	320	4	no
1176-200WL							built-in wireless

(mm)

D2	L2
Ø17	<16
Ø18	<28
Ø19	<40
Ø20	<50
Ø21	<58
Ø22~150	<70

IP67 dust/waterproof(no data output, no automatic power off, set zero after power on each time, no preset)

(mm)

Code	Range of upper jaw	Range of lower jaw	Type	Accuracy	a
1176-150P	9-150mm/0.35-6"	17-150mm/0.70-6"	B	±0.04mm	4

(mm)

D1	L1
Ø9	<8
Ø10	<15
Ø11~200	<30