

TURNING

THREADING

GROOVING

MILLING

DRILLING

ACCESSORIES

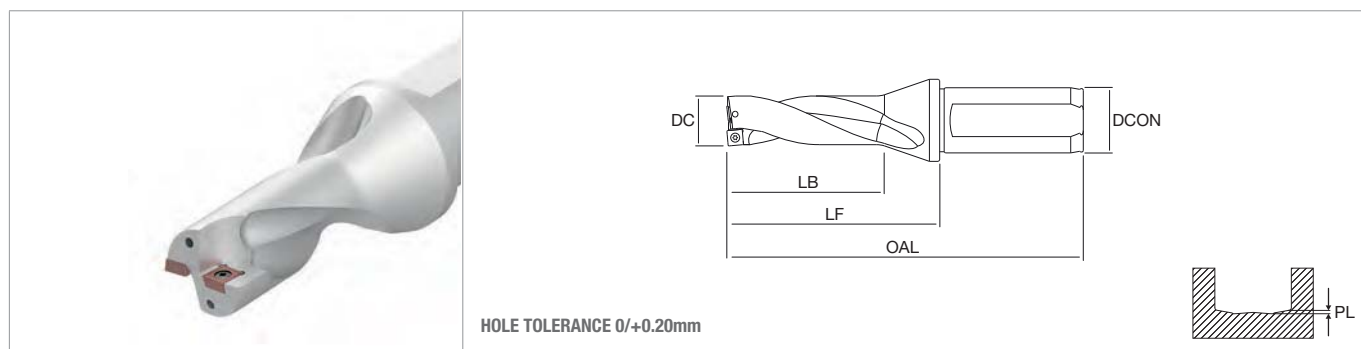

DRS 2XD			DC	DCON	OAL	LF	LB	ADJLX max. radial offset	PL hole bottom shape	MIID
---------	--	--	----	------	-----	----	----	--------------------------------	----------------------------	------

05	NT-DRS-2D	D13.00-S20-05	●	13	20	94	44	26	0.50	0.40	SPMX05 SPGX05
		D14.00-S20-05	●	14	20	96	46	28	0.50	0.40	
		D15.00-S20-05	●	15	20	99	49	30	0.50	0.40	
06	NT-DRS-2D	D16.00-S25-06	●	16	25	108	52	32	0.50	0.50	SPMX06 SPGX06
		D17.00-S25-06	●	17	25	110	54	34	0.50	0.50	
		D18.00-S25-06	●	18	25	113	57	36	0.50	0.50	
		D19.00-S25-06	●	19	25	115	59	38	0.50	0.50	
		D20.00-S25-06	●	20	25	119	63	40	0.50	0.50	
		D21.00-S25-06	●	21	25	121	65	42	0.25	0.50	
07	NT-DRS-2D	D22.00-S25-07	●	22	25	123	67	44	0.50	0.50	SPMX07 SPGX07
		D23.00-S32-07	●	23	32	131	71	46	0.50	0.50	
		D24.00-S32-07	●	24	32	134	74	48	0.50	0.50	
		D25.00-S32-07	●	25	32	137	77	50	0.50	0.50	
		D26.00-S32-07	●	26	32	139	79	52	0.25	0.60	
		D27.00-S32-07	●	27	32	141	81	54	0.25	0.60	
09	NT-DRS-2D	D28.00-S32-09	●	28	32	144	84	56	0.50	0.80	SPMX09 SPGX09
		D29.00-S32-09	●	29	32	146	86	58	0.50	0.80	
		D30.00-S32-09	●	30	32	151	91	60	0.50	0.80	
		D31.00-S32-09	●	31	32	154	94	62	0.25	0.80	
		D32.00-S32-09	●	32	32	156	96	64	0.25	0.80	
		D33.00-S32-09	●	33	32	159	99	66	0.25	0.80	
11	NT-DRS-2D	D34.00-S40-11	●	34	40	171	101	68	0.50	0.90	SPMX11 SPGX11
		D35.00-S40-11	●	35	40	174	104	70	0.50	0.90	
		D36.00-S40-11	●	36	40	177	107	72	0.50	0.90	
		D37.00-S40-11	●	37	40	180	110	74	0.50	0.90	
		D38.00-S40-11	●	38	40	183	113	76	0.50	0.90	
		D39.00-S40-11	●	39	40	185	115	78	0.50	0.90	
		D40.00-S40-11	●	40	40	188	118	80	0.25	0.90	
		D41.00-S40-11	●	41	40	191	121	82	0.25	0.90	
14	NT-DRS-2D	D42.00-S40-14	●	42	40	193	123	84	0.50	1.00	SPMX14 SPGX14
		D43.00-S40-14	●	43	40	196	126	86	0.50	1.00	
		D44.00-S40-14	●	44	40	198	128	88	0.50	1.00	
		D45.00-S40-14	●	45	40	202	132	90	0.50	1.00	
		D46.00-S40-14	●	46	40	205	135	92	0.50	1.00	
		D47.00-S40-14	●	47	40	207	137	94	0.50	1.00	
		D48.00-S40-14	●	48	40	210	140	96	0.25	1.00	
		D49.00-S40-14	●	49	40	212	142	98	0.25	1.00	
		D50.00-S40-14	●	50	40	215	145	100	0.25	1.00	

● stock standard

Spare Parts	INSERT SCREW	INSERT WRENCH

NT-DRS-2D D <sub>00.00</sub> -S <sub>00</sub> -05	NT-ST059	NT-FTB06
NT-DRS-2D D <sub>00.00</sub> -S <sub>00</sub> -06	NT-ST061	NT-FTB06
NT-DRS-2D D <sub>00.00</sub> -S <sub>00</sub> -07	NT-ST062	NT-FTB07
NT-DRS-2D D <sub>00.00</sub> -S <sub>00</sub> -09	NT-ST063	NT-FTB15
NT-DRS-2D D <sub>00.00</sub> -S <sub>00</sub> -11	NT-ST064	NT-FTB15
NT-DRS-2D D <sub>00.00</sub> -S <sub>00</sub> -14	NT-ST066	NT-FTB20