

Verstellschrauben für Weldon Whistle Notch DIN 1835 E



Adjusting Screws for Weldon chucks whistle notch DIN 1835 E
 Vis de réglage pour mandrins Weldon whistle notch DIN 1835 E



Verwendung:
 Zur Längeneinstellung des Schneidwerkzeugs
Application:
 For length adjustment of cutting tools
Application:
 Pour le réglage de la longueur de l'outil de coupe

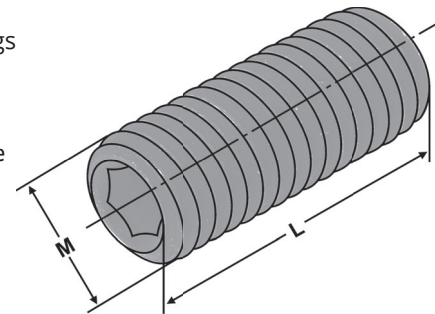

Bestell-Nr. Order no. Référence	M	L	für Durchmesser for diameter pour diamètre
102.05.06	M5x0,8	30	6
102.05.08	M6x1,0	30	8
102.05.10	M8x1,25	30	10
102.05.12	M10x1,5	30	12+14
102.05.16	M12x1,75	30	16+18
102.05.20	M16x2,0	30	20
102.05.25	M20x2,5	25	25+32+40

Verstellschrauben für Spannfutter

Adjusting Screws for collet chucks
 Vis de réglage pour mandrin de serrage



Verwendung:
 Zur Längeneinstellung des Schneidwerkzeugs
Application:
 For length adjustment of cutting tools
Application:
 Pour le réglage de la longueur de l'outil de coupe

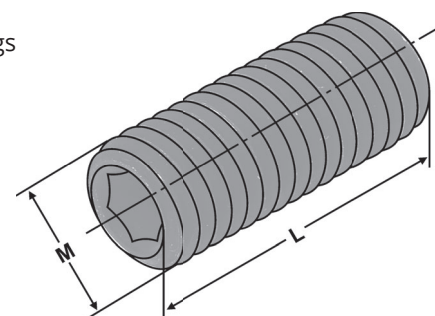

10

Bestell-Nr. Order no. Référence	M	L
101.02.05	M10 x 1,5 (ER16)	20
101.02.10	M12 x 1,75 (ER20)	20
101.02.15	M16 x 2,0 (ER25 + ER32 + ER40)	20