



# Gewindebohrer Spannzangen mit Kühkanalbohrungen

Tap collets with cooling channels  
Pincettes de serrage avec canaux d'arrosage



**Verwendung:**  
Für Maschinen mit steigungssynchronem Vorschub. Zur verdrehsicheren Spannung von Gewindebohrern.

**Application:**  
For machines with rigid tapping. For safe clamping of taps.

**Application:**  
Pour machines avec broche synchronisée. Pour le serrage stable de tarauds.

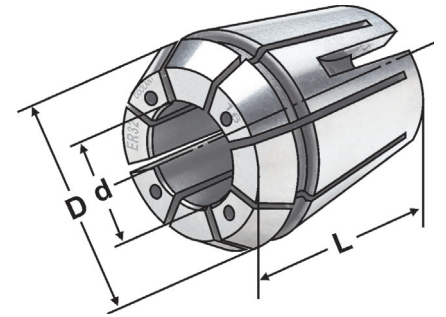

ISO 15488 B  
DIN 6499 B

ER

$\nabla \leq 0,015$



Bestell-Nr. Order no. Référence	Größe Size Taille	Schaft Shaft Queue	Vierkant Square Carré	D	L
428GC-3527	ER 20	3,5	2,7	20,8	31,5
428GC-43	ER 20	4	3	20,8	31,5
428GC-4534	ER 20	4,5	3,4	20,8	31,5
428GC-649	ER 20	6	4,9	20,8	31,5
428GC-755	ER 20	7	5,5	20,8	31,5
428GC-862	ER 20	8	6,2	20,8	31,5
428GC-97	ER 20	9	7	20,8	31,5
428GC-108	ER 20	10	8	20,8	31,5

