



ohne Längenausgleich auf Druck und Zug

DIN 69880 (VDI 3425)

Quick change tapping chucks without length compensation on compression and expansion
 Mandrins de taraudage à changement rapide sans compensation longitudinale à la compression et traction



Verwendung:
 Für Bearbeitungszentren mit Synchronspindel. Zur Aufnahme von Schnellwechsel-Einsätzen für Gewindebohrer.

Application:
 On machining centres with synchronised spindles. For the chucking of Quick change taps for threading taps.

Application:
 Sur centres d'usinage avec axe synchrone. Pour le serrage des inserts de changement rapide pour tarauds.

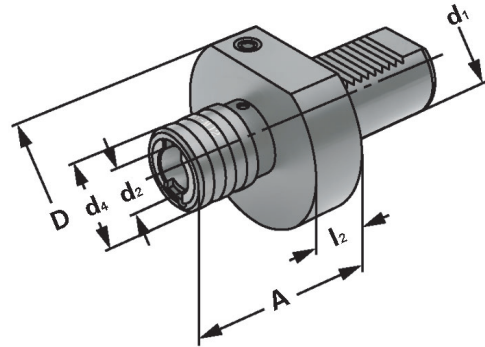

ISO 10889
 DIN 69880

14.04

Bestell-Nr. Order no. Référence	d ₁	Spannbereich Capacity Capacité	Größe Size Taille	D	A	d ₄	d ₂
309.16.12.1	30	M3 - M14	1	68	55	36	19
309.16.20.1	30	M5 - M22	2	68	77	53	31
409.16.12.1	40	M3 - M14	1	83	55	36	19
409.16.20.1	40	M5 - M22	2	83	77	53	31

