



Quick change tapping chucks **with** length compensation on compression and expansion

Mandrins de taraudage à changement rapide **avec** compensation longitudinale à la compression et traction



Verwendung:

Zur Aufnahme von Schnellwechsel-Einsätzen für Gewindebohrer.

Application:

For the chucking of Quick change taps for threading taps.

Application:

Pour le serrage des inserts de changement rapide pour tarauds.

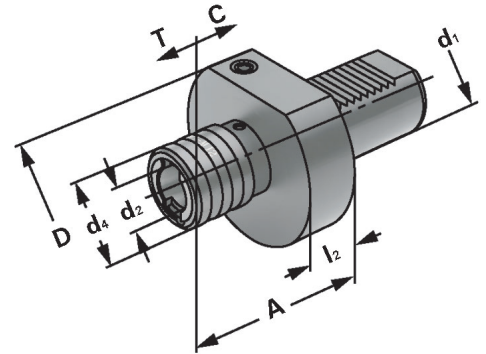

ISO 10889
DIN 69880

14.04

Bestell-Nr. Order no. Référence	d ₁	Spannbereich Capacity Capacité	Größe Size Taille	D	A	d ₄	d ₂	C	T
209.16.12	20	M3 - M14	1	50	67	38	19	7	7
259.16.12	25	M3 - M14	1	58	55	38	19	7	7
309.16.12	30	M3 - M14	1	58	58	36	19	7	7
309.16.20	30	M5 - M22	2	81	81	53	31	12	12
409.16.12	40	M3 - M14	1	58	58	36	19	7	7
409.16.20	40	M5 - M22	2	81	81	53	31	12	12
509.16.12	50	M3 - M14	1	58	56	36	19	7	7
509.16.20	50	M5 - M22	2	81	80	53	31	12	12

