



Axial toolholders form C4 overhead left - for tools with internal coolant
 Porte-outils axials forme C4 inversés gauche - pour outils avec arrosage interne



Verwendung:
 Vorwiegend für Außenbearbeitung.
 Zum Plan Einstechen.

Application:
 Mainly for external machining.
 For face machining.

Application:
 Principalement pour usinage extérieur.
 Pour carottage.

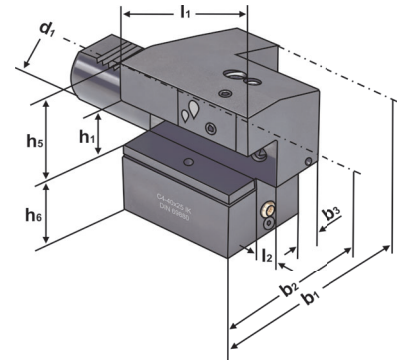

ISO 10889
 DIN 69880

C4

IC

Bestell-Nr. Order no. Référence	Abmessung Size Dimension	d1	h1	b1	b2	b3	l1	l2	h5	h6
309.44.20.IK	C4 - 30 × 20	30	20	70	35	17	70	10	38	35
409.44.25.IK	C4 - 40 × 25	40	25	85	42,5	21	85	12,5	48	42,5
509.44.32.IK	C4 - 50 × 32	50	32	100	50	26	100	16	60	50

Ausführung: Mit einstellbarer Kugelspritzdüse
Version: With adjustable spray nozzle
Version: Avec gicleur ajustable

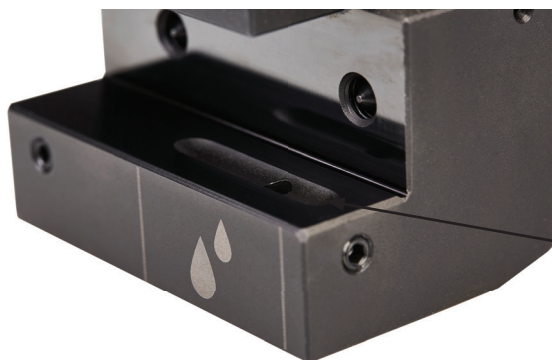

Übergabe für Kühlmittel
 Coolant supply
 Jonction d'arrosage

