



Axial toolholders form C3 overhead right - for tools with internal coolant
 Porte-outils axials forme C3 inversés droite - pour outils avec arrosage interne



Verwendung:
 Vorwiegend für Außenbearbeitung.
 Zum Plan Einstechen.

Application:
 Mainly for external machining.
 For face machining.

Application:
 Principalement pour usinage extérieur.
 Pour carottage.

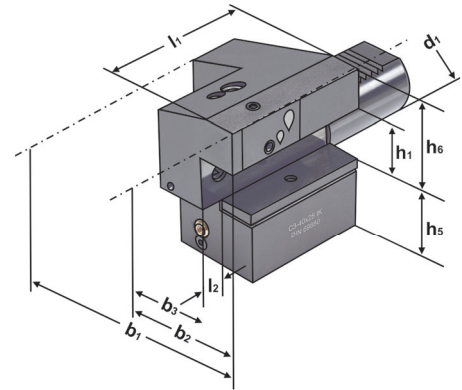

| Bestell-Nr. Order no. Référence | Abmessung Size Dimension | d1 | h1 | b1 | b2 | b3 | l1 | l2 | h5 | h6 |
|---------------------------------------|--------------------------------|----|----|-----|------|----|-----|------|----|------|
| 309.43.20.IK | C3 - 30 × 20 | 30 | 20 | 70 | 35 | 17 | 70 | 10 | 38 | 35 |
| 409.43.25.IK | C3 - 40 × 25 | 40 | 25 | 85 | 42,5 | 21 | 85 | 12,5 | 48 | 42,5 |
| 509.43.32.IK | C3 - 50 × 32 | 50 | 32 | 100 | 50 | 26 | 100 | 16 | 60 | 50 |

Ausführung: Mit einstellbarer Kugelspritzdüse
Version: With adjustable spray nozzle
Version: Avec gicleur ajustable

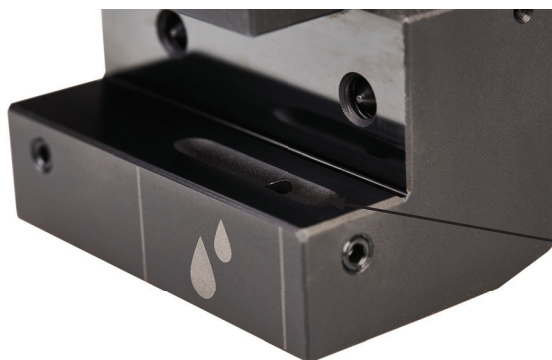

Übergabe für Kühlmittel
 Coolant supply
 Jonction d'arrosage

