



Radial toolholders form B8 overhead left, long
 Porte-outils radials forme B8 inversé gauche, long

DIN 69880 (VDI 3425)



Verwendung:
 Vorwiegend für Außenbearbeitung.
 Zum Plan Einstechen.

Application:
 Mainly for external machining.
 For face machining.

Application:
 Principalement pour usinage extérieur.
 Pour carottage.

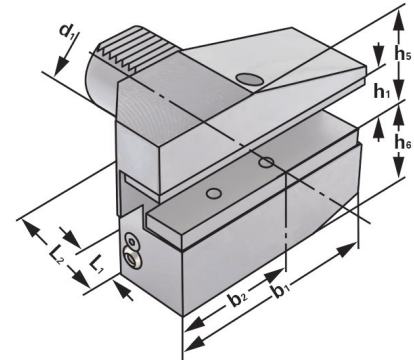

ISO 10889
 DIN 69880

B8

Bestell-Nr. Order no. Référence	Abmessung Size Dimension	d ₁	b ₁	b ₂	b ₃	L ₁	L ₂	h ₁	h ₅	h ₆
169.38.12	B8 - 16 × 12 × 24	16	58	39	5	13	24	12	20	22
209.38.16	B8 - 20 × 16 × 30	20	75	50	7	16	30	16	30	25
259.38.16	B8 - 25 × 16 × 30	25	75	50	7	16	30	16	30	25
309.38.20	B8 - 30 × 20 × 40	30	100	65	10	22	40	20	38	35
409.38.25	B8 - 40 × 25 × 44	40	118	75,5	12,5	22	44	25	48	42,5
509.38.32	B8 - 50 × 32 × 55	50	130	80	16	30	55	32	60	50



Ausführung: Mit einstellbarer Kugelspritzdüse und Unterlegplatte
Version: With adjustable spray nozzle and shim
Version: Avec gicleur ajustable et semelle

