



Radial toolholders form B1 right, short - for tools with internal coolant
 Porte-outils radials forme B1 droite, pour - outils avec arrosage interne



Verwendung:
 Vorwiegend für Außenbearbeitung.
 Zum Plan Einstechen.

Application:
 Mainly for external machining.
 For face machining.

Application:
 Principalement pour usinage extérieur.
 Pour carottage.

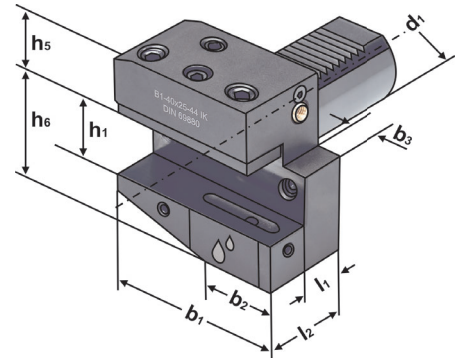

ISO 10889
 DIN 69880

B1

IC

Bestell-Nr. Order no. Référence	Abmessung Size Dimension	d ₁	h ₁	l ₂	l ₁	b ₁	b ₂	b ₃	h ₅	h ₆
309.31.20.IK	B1 - 30 × 20 × 40	30	20	40	22	70	35	10	28	38
409.31.25.IK	B1 - 40 × 25 × 44	40	25	44	22	85	42,5	12,5	32,5	48
509.31.32.IK	B1 - 50 × 32 × 55	50	32	55	30	100	50	16	35	60

Ausführung: Mit einstellbarer Kugelspritzdüse
Version: With adjustable spray nozzle
Version: Avec gicleur ajustable

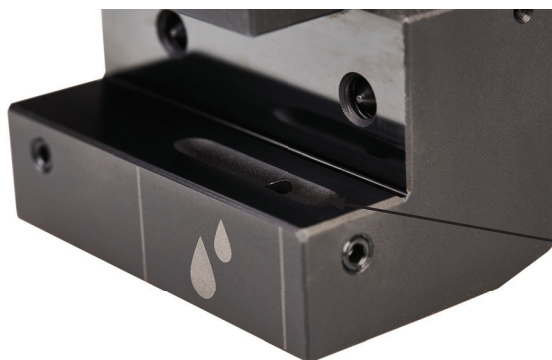

Übergabe für Kühlmittel
 Coolant supply
 Jonction d'arrosage

