



auf Druck und Zug

Quick change tapping chucks with length compensation on compression and expansion  
 Mandrins de taraudage à changement rapide avec compensation longitudinale à la compression et traction



**Verwendung:**  
 Zur Aufnahme von Schnellwechsel-Einsätzen für Gewindebohrer.

**Application:**  
 For the chucking of quick change adaptors for taps.

**Application:**  
 Pour le serrage d'adapteurs portetarauds à changement rapide.

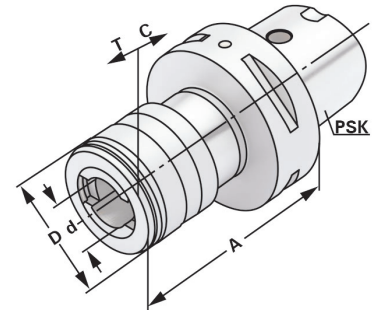

ISO 26623 G2,5  
 25.000 min<sup>-1</sup>



| Bestell-Nr.<br>Order no.<br>Référence | PSK | Spannbereich<br>Capacity<br>Capacité | Größe<br>Size<br>Taille | A   | D  | d  | T    | C    |
|---------------------------------------|-----|--------------------------------------|-------------------------|-----|----|----|------|------|
| C4.16.12                              | C4  | M3 - M14                             | 1                       | 68  | 41 | 19 | 7,5  | 7,5  |
| C4.16.20                              | C4  | M5 - M22                             | 2                       | 91  | 60 | 31 | 10   | 10   |
| C5.16.12                              | C5  | M3 - M14                             | 1                       | 68  | 41 | 19 | 7,5  | 7,5  |
| C5.16.20                              | C5  | M5 - M22                             | 2                       | 91  | 60 | 31 | 10   | 10   |
| C6.16.12                              | C6  | M3 - M14                             | 1                       | 73  | 41 | 19 | 7,5  | 7,5  |
| C6.16.20                              | C6  | M5 - M22                             | 2                       | 97  | 60 | 31 | 10   | 10   |
| C6.16.36                              | C6  | M14 - M36                            | 3                       | 146 | 86 | 48 | 17,5 | 17,5 |



**Hinweis:** Für Bearbeitungszentren ohne Synchronspindel.  
**Note:** For machining centres without synchronous spindle.  
**Observation:** Pour centres d'usinage sans broche synchrone.

