



Quick change tapping chucks with length compensation on compression and expansion
Mandrins de taraudage à changement rapide avec compensation longitudinale à la compression et traction



Verwendung:
Zur Aufnahme von Schnellwechsel-Einsätzen für Gewindebohrer.

Application:
For the chucking of quick change adaptors for taps.

Application:
Pour le serrage d'adapteurs porte-tarauts à changement rapide.

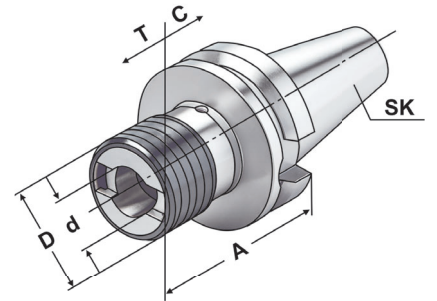

3

JIS B 6339

Form A

Bestell-Nr. Order no. Référence	SK	Spannbereich Capacity Capacité	Größe Size Taille	A	D	d	C	T
DC.405.16.12	BT 40	M3 - M14	1	65	38	19	7	7
DC.405.16.20	BT 40	M5 - M22	2	93	54	31	12	12

Hinweis: Für Bearbeitungszentren ohne Synchronspindel.
Note: For machining centres without synchronous spindle.
Observation: Pour centres d'usinage sans broche synchrone.

