

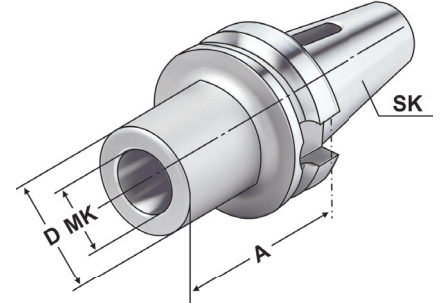

Verwendung:
Zur Aufnahme von Werkzeugen mit Morsekegelschaft und Austreibblappen nach DIN 228-1 Form B.

Application:
For mounting tools with Morse taper shank and tang according to DIN 228-1 form B.

Application:
Pour le serrage d'outils avec queue cône Morse et tenon suivant DIN 228-1 forme B.



JIS B 6339  AD/B  $\leq 0,005$  G6,3 15.000 min⁻¹

Bestell-Nr. Order no. Référence	SK	MK MT CM	A	D
DC.305.07.01 *	BT 30	1	45	25
DC.305.07.02 *	BT 30	2	60	32
DC.305.07.03 *	BT 30	3	75	40
DC.406.07.01	BT 40	1	50	25
DC.406.07.02	BT 40	2	50	32
DC.406.07.03	BT 40	3	70	40
DC.406.07.04	BT 40	4	95	48

- * JIS B 6339 Form AD
- * JIS B 6339 form AD
- * JIS B 6339 forme AD

Gewuchtete Ausführung

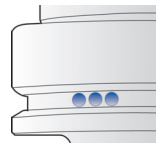

Balanced type
Type équilibré

Bestell-Nr. Order no. Référence	Abmessung Size Dimension
---------------------------------------	--------------------------------

Wuchten auf G 2,5 von vorgewuchteten Kemmler-Werkzeugen

Balancing at G 2.5 of pre-balanced Kemmler-tools
Équilibrage sur G 2,5 d'outils Kemmler pré-équilibrés

W25 **Ohne Wuchtprotokoll**
Without balancing report
Sans protocole d'équilibrage

W25.2 **Mit Wuchtprotokoll**
With balancing report
Avec protocole d'équilibrage

Wuchten von nicht vorgewuchteten Werkzeugen
Balancing of unbalanced tools
Équilibrage d'outils non-équilibrés

W25.1 **Ohne Wuchtprotokoll**
Without balancing report
Sans protocole d'équilibrage

