

MIKROMILL

Nut- und Formzirkularfräsen

groove milling
by circular interpolation

Typ MB6 / MB8

Vorwärts- und Rückwärtsfasen

forward and backward chamfering

Bohrungs-Ø ab 6 / 8 mm

bore Ø from 6 / 8 mm

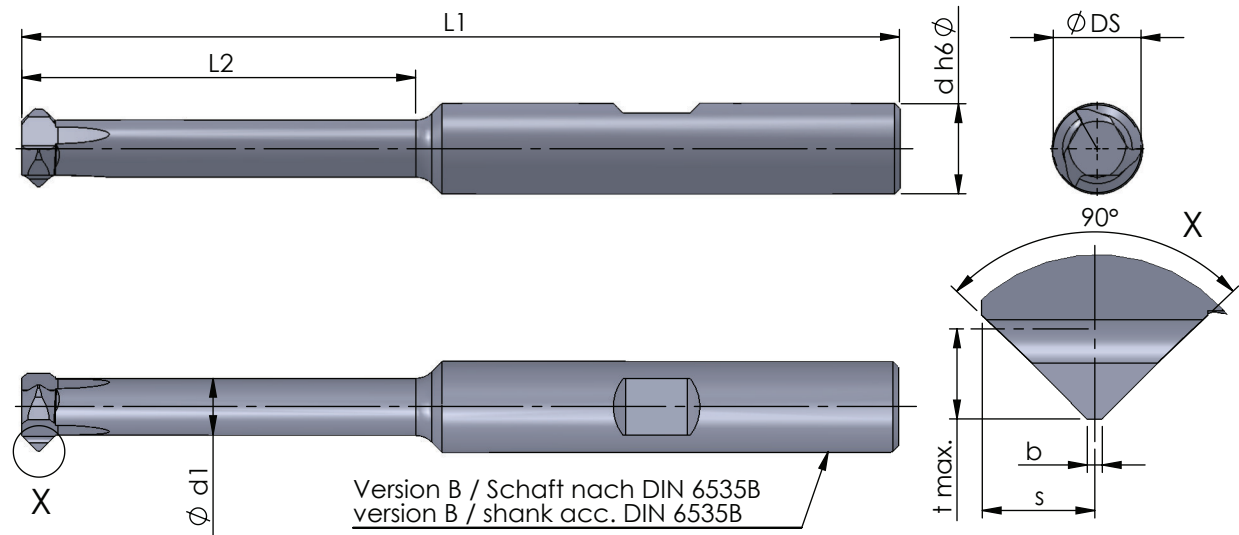

Abmessungen in mm

dimensions in mm



Bestellnummer part number	Abmessungen in mm / dimensions in mm										Material		
	D min.	b	L2	L1	s	Ø d h6	Ø d1	Ø DS	t max.	Schneidenzahl cutting edge	K10F	AL41F	P18C
MB6.4545.02-15	6	0.2	15	58	1	6	4.2	5.8	0.6	3	●	●	
MB6.4545.02-25	6	0.2	25	68	1	6	4.2	5.8	0.6	3	●	●	
MB8.4545.02-25	8	0.2	25	68	1.5	8	5	7.8	1.2	3	●	●	
MB8.4545.02-35	8	0.2	35	78	1.5	8	5	7.8	1.2	3	●	●	

Weitere HM Sorten können Sie in der Sortenübersicht im Kapitel "Technische Hinweise" und der Preisliste finden.

Bestellbeispiel:
für Sorte AL41F:
MB6.4545.02-15/AL41F

More carbide grades you can find in the grades summary in the chapter "technical instructions" and in the price list.

order-example:
grade AL41F:
MB6.4545.02-15/AL41F