

MWR Bars Chamfering and Profiling

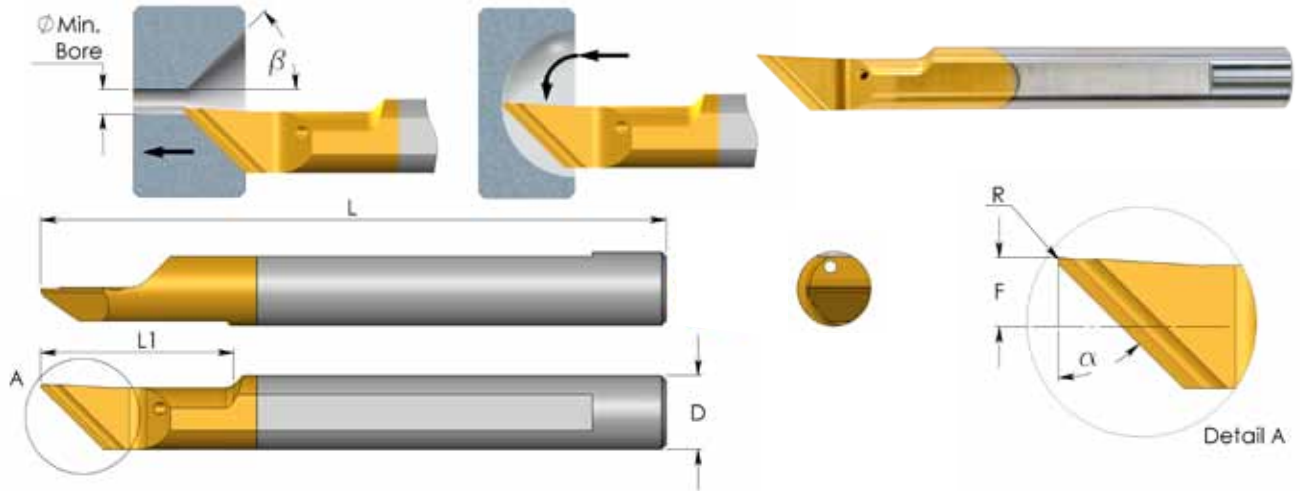

D	Ordering Code	L	L1	R	α	β	F	Min. Bore Dia.	Holder*
6.0	MWR 6 R0.2 A90	51	15.0	0.2	45°	45°	2.3	1.0	SIM ... H6
	MWR 6 R0.2 A60	51	15.0	0.2	60°	30°	2.3	1.0	
	* MWR 6 R0.4 A90	51	22.0	0.4	45°	45°	2.3	6.0	
	* MWR 6 R0.4 A60	51	22.0	0.4	60°	30°	2.3	6.0	

Order example: MWR 6 R0.2 A90 BXC

For L.H. bars specify MWL instead of MWR

*Can be used also for boring

** For additional holders see page 100