

MCR Bars Chamfering and Boring

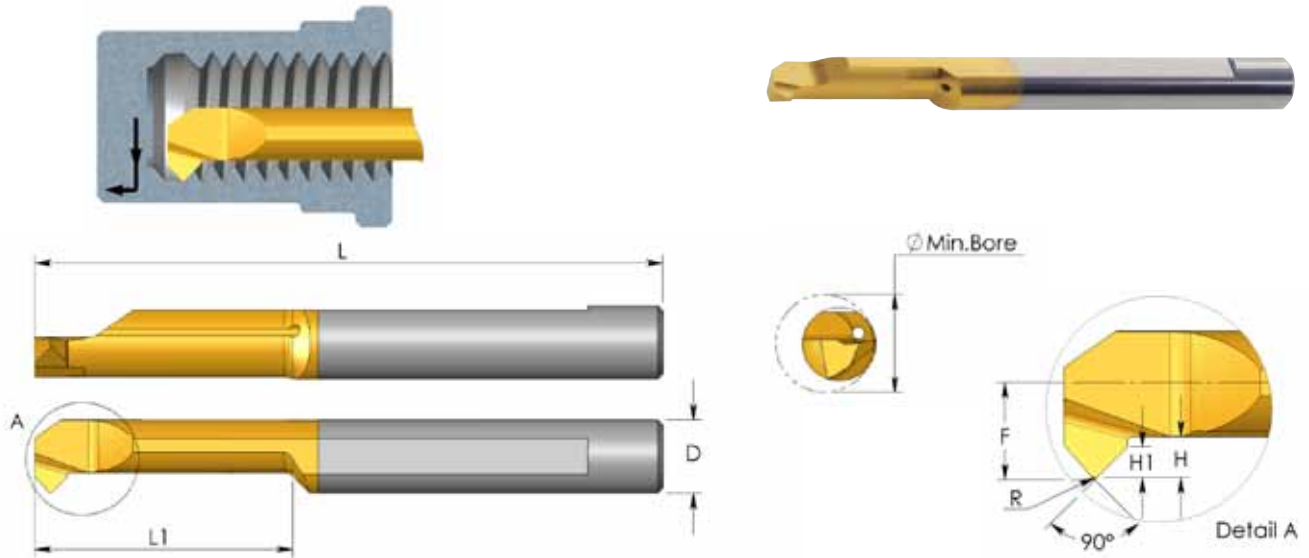

D	Ordering Code	L	L1	R	H	H1	F	Min. Bore Dia.	Holder*
3.0	MCR 3 R0.2 L10	39	10	0.2	0.7	0.3	1.3	3.1	SIM ... H3
4.0	MCR 4 R0.2 L15	51	15	0.2	0.8	0.4	1.7	4.1	SIM ... H4
5.0	MCR 5 R0.2 L15	51	15	0.2	1.2	0.7	2.1	5.1	SIM ... H5
6.0	MCR 6 R0.2 L15	51	15	0.2	1.4	0.7	2.8	6.1	SIM ... H6
7.0	MCR 7 R0.2 L20	62	20	0.2	1.5	0.8	3.3	7.1	SIM ... H7

Order example: MCR 4 R0.2 L15 BXC

For L.H. bars specify MCL instead of MCR

* For additional holders see page 100