

MIR Bars Threading

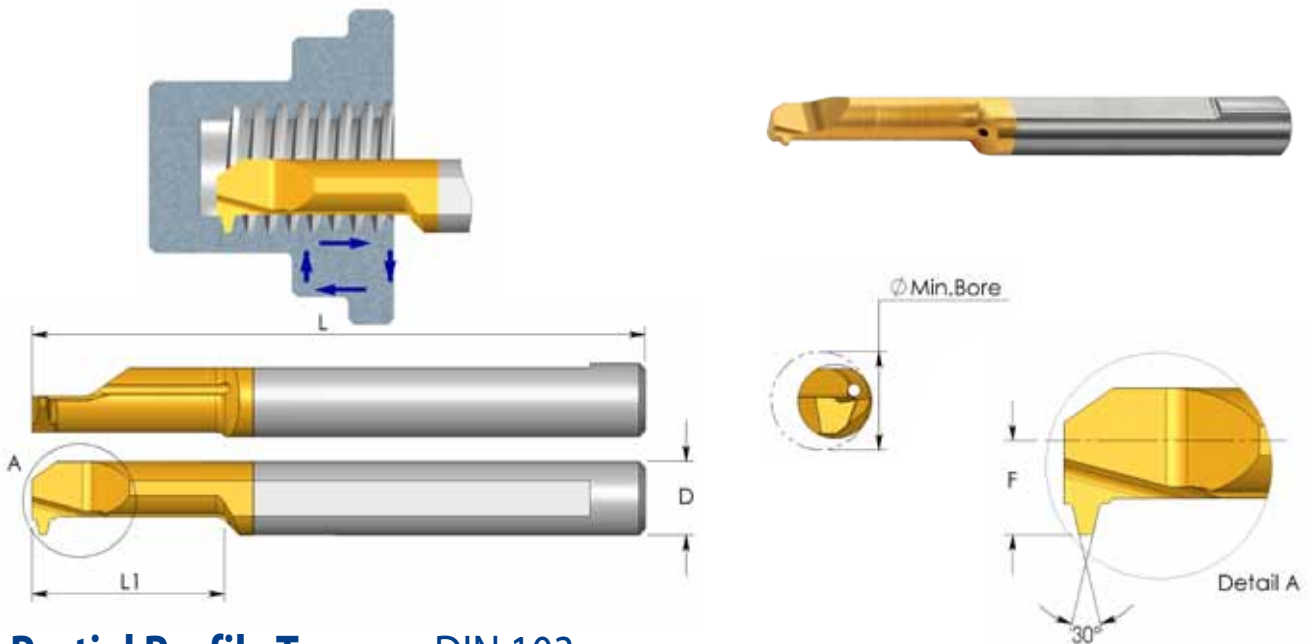

Partial Profile Trapez - DIN 103

D	Ordering Code	Pitch mm	Thread Size	L	L1	F	Min. Bore Dia.	Holder*
6.0	MIR 6 L22 1.5 TR	1.5	Tr8x1.5 Tr9x1.5 Tr10x1.5	51	22	2.8	6.4	SIM ... H6
7.0	MIR 7 L25 2 TR	2	Tr 9 x 2 Tr10 x 2 Tr11 x 2 Tr12 x 2	62	25	3.2	6.9	SIM ... H7
10.0	MIR 10 L35 2 TR	2	Tr14 x 2 Tr16 x 2 Tr18 x 2 Tr20 x 2	73	35	4.8	11.0	SIM ... H10
7.0	MIR 7 L35 3 TR	3	Tr11 x 3 Tr12 x 3	62	35	3.3	7.5	SIM ... H7
10.0	MIR 10 L35 3 TR	3	Tr14 x 3 Tr22 x 3 Tr24 x 3 Tr26 x 3 Tr28 x 3	73	35	4.8	10.5	SIM ... H10
10.0	MIR 10 L45 4 TR	4	Tr16 x 4 Tr18 x 4 Tr20 x 4	105	45	4.8	11.5	SIM ... H10
10.0	MIR 10 L55 5 TR	5	Tr22 x 5 Tr24 x 5 Tr28 x 5	105	55	4.8	11.0	SIM ... H10

Order example: MIR 10 L35 3 TR BXC

For L.H. bars specify MIL instead of MIR

* For additional holders see page 100