

MQR Bars Profiling and Boring

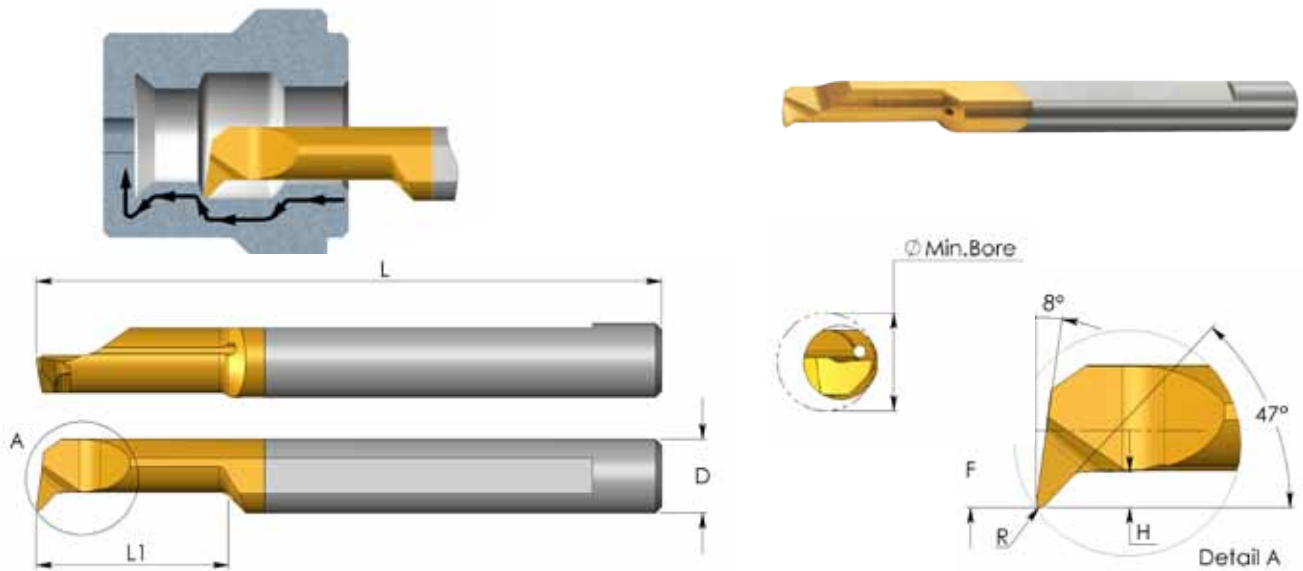

D	Ordering Code	L	L1	R	H	F	Min. Bore Dia.	Holder*
4.0	MQR 4 R0.1 L22	51	22	0.10	0.8	1.8	4.1	SIM ... H4
	MQR 4 R0.2 L10	51	10	0.20	0.8	1.8	4.1	
	MQR 4 R0.2 L15	51	15	0.20	0.8	1.8	4.1	
	MQR 4 R0.2 L22	51	22	0.20	0.8	1.8	4.1	
5.0	MQR 5 R0.2 L15	51	15	0.20	1.0	2.3	5.1	SIM ... H5
	MQR 5 R0.2 L22	51	22	0.20	1.0	2.3	5.1	
6.0	MQR 6 R0.2 L15	51	15	0.20	1.4	2.8	6.1	SIM ... H6
	MQR 6 R0.2 L22	51	22	0.20	1.4	2.8	6.1	
	MQR 6 R0.2 L30	58	30	0.20	1.4	2.8	6.1	
8.0	MQR 8 R0.2 L22	64	22	0.20	1.6	3.8	8.1	SIM ... H8
	MQR 8 R0.2 L27	64	27	0.20	2.0	3.8	8.1	

Order example: MQR 5 R0.2 L15 BXC

For L.H. bars specify MQR instead of MQL

* For additional holders see page 100