

MTR Bars Boring

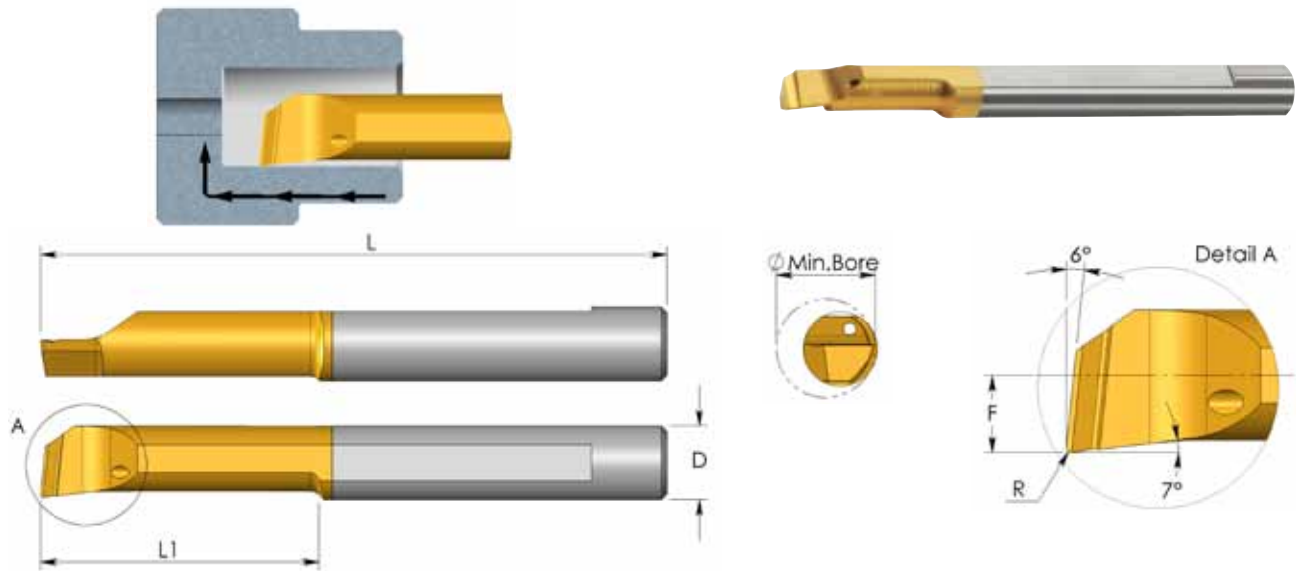

D	Ordering Code	L	L1	R	F	Min. Bore Dia.	Holder*
3.0	MTR 1 R0.05 L4	39	4	0.05	0.5	1.0	SIM ... H3
	MTR 1 R0.05 L6	39	6	0.05	0.5	1.0	
	MTR 1.5 R0.1 L6	39	6	0.10	0.7	1.5	
3.0	MTR 2 R0.05 L10	39	10	0.05	0.8	2.1	SIM ... H3
	MTR 2 R0.15 L5	39	5	0.15	0.8	2.1	
	MTR 2 R0.15 L10	39	10	0.15	0.8	2.1	
3.0	MTR 3 R0.05 L10	39	10	0.05	1.3	3.1	SIM ... H3
	MTR 3 R0.05 L15	39	15	0.05	1.3	3.1	
	MTR 3 R0.1 L10	39	10	0.10	1.3	3.1	
	MTR 3 R0.1 L15	39	15	0.10	1.3	3.1	
	MTR 3 R0.2 L10	39	10	0.20	1.3	3.1	
	MTR 3 R0.2 L15	39	15	0.20	1.3	3.1	
4.0	MTR 4 R0.05 L15	51	15	0.05	1.7	4.1	SIM ... H4
	MTR 4 R0.1 L10	51	10	0.10	1.7	4.1	
	MTR 4 R0.1 L15	51	15	0.10	1.7	4.1	
	MTR 4 R0.1 L22	51	22	0.10	1.7	4.1	
	MTR 4 R0.2 L10	51	10	0.20	1.7	4.1	
	MTR 4 R0.2 L15	51	15	0.20	1.7	4.1	
	MTR 4 R0.2 L22	51	22	0.20	1.7	4.1	
	MTR 4 R0.2 L30	59	30	0.20	1.7	4.1	

* For additional holders see page 100