

DIN 787

Bolts for T-slots, complete

with hexagon nut DIN 6330B and washer DIN 6340.
 Forged, milled T-groove, rolled thread, stamped with AMF logo and strength class. M6 to M12 hardened to strength class 10.9, M14 to M42 hardened to strength class 8.8.

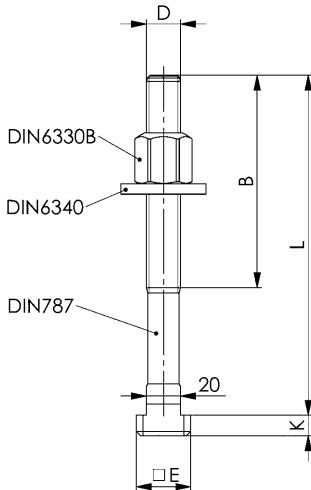

Order no.	D x Slot x L	A	B	E	K	Weight [g]
84202	M6x6x25	5,7	15	10	4	19
84210	M6x6x40	5,7	28	10	4	22
84228	M6x6x63	5,7	40	10	4	28
84236	M8x8x32	7,7	22	13	6	40
80812	M8x8x50	7,7	35	13	6	45
80820	M8x8x80	7,7	50	13	6	55
84244	M10x10x40	9,7	30	15	6	65
80838	M10x10x63	9,7	45	15	6	80
81356	M10x10x80	9,7	50	15	6	90
80846	M10x10x100	9,7	60	15	6	110
80853	M12x12x50	11,7	35	18	7	120
85746	M12x12x63	11,7	40	18	7	128
80861	M12x12x80	11,7	55	18	7	130
81448	M12x12x100	11,7	65	18	7	145
80879	M12x12x125	11,7	75	18	7	170
81505	M12x12x160	11,7	100	18	7	195
80887	M12x12x200	11,7	120	18	7	220
80895	M12x14x50	13,7	35	22	8	130
85753	M12x14x63	13,7	45	22	8	145
80903	M12x14x80	13,7	55	22	8	155
82974	M12x14x100	13,7	65	22	8	155
80911	M12x14x125	13,7	75	22	8	180
84376	M12x14x160	13,7	100	22	8	210
80929	M12x14x200	13,7	120	22	8	240
80937	M14x16x63	15,7	45	25	9	200
84442	M14x16x80	15,7	55	25	9	220
80945	M14x16x100	15,7	65	25	9	230
84459	M14x16x125	15,7	75	25	9	280
80952	M14x16x160	15,7	100	25	9	310
80960	M14x16x250	15,7	120	25	9	390
80978	(M16x16x63)	15,7	45	25	9	250
85761	(M16x16x80)	15,7	55	25	9	275
80986	(M16x16x100)	15,7	65	25	9	290
84392	(M16x16x125)	15,7	85	25	9	300
80994	(M16x16x160)	15,7	100	25	9	380
85779	(M16x16x200)	15,7	125	25	9	435
81000	(M16x16x250)	15,7	150	25	9	530
81018	M16x18x63	17,7	45	28	10	260
85787	M16x18x80	17,7	55	28	10	305
81026	M16x18x100	17,7	65	28	10	315
84418	M16x18x125	17,7	85	28	10	360
81034	M16x18x160	17,7	100	28	10	400
85795	M16x18x200	17,7	125	28	10	448
81042	M16x18x250	17,7	150	28	10	560
84301	(M20x20x80)	19,7	55	32	12	520
81547	(M20x20x100)	19,7	65	32	12	570
84319	(M20x20x125)	19,7	85	32	12	560
85803	(M20x20x160)	19,7	110	32	12	680
84327	(M20x20x200)	19,7	125	32	12	700
81562	(M20x20x250)	19,7	150	32	12	800
84335	(M20x20x315)	19,7	190	32	12	940
81059	M20x22x80	21,7	55	35	14	530
85837	M20x22x100	21,7	65	35	14	610
81067	M20x22x125	21,7	85	35	14	670
85811	M20x22x160	21,7	110	35	14	710
81075	M20x22x200	21,7	125	35	14	750
85852	M20x22x250	21,7	150	35	14	850
81083	M20x22x315	21,7	190	35	14	980
81216	(M24x24x100)	23,7	70	40	16	910
85860	(M24x24x125)	23,7	85	40	16	970
81224	(M24x24x160)	23,7	110	40	16	1040
85878	(M24x24x200)	23,7	125	40	16	1265
81232	(M24x24x250)	23,7	150	40	16	1410
81588	(M24x24x315)	23,7	190	40	16	1640
81240	(M24x24x400)	23,7	240	40	16	1780
81091	M24x28x100	27,7	70	44	18	980
85886	M24x28x125	27,7	85	44	18	1010
81109	M24x28x160	27,7	110	44	18	1150
85894	M24x28x200	27,7	125	44	18	1240

Subject to technical alterations.