



Drilling and milling head, angular, left hand, short
collet chuck, ER50A, PRECI-FLEX®, external and central coolant
supply

číslo součásti 9.910.136
pro Okuma LB/LU45-M

poměr 1:1
otáčky na vstupu max. 4000 1/min.
otáčky na výstupu max. 4000 1/min.
Krouticí moment max. 200 Nm
Směr otáčení 
Rozsah dodání without wrench and collets
* Actual size inscribed on the tool



Příslušen. Collets see Equipment for Toolholders Z2.1
Sealing washers see Equipment for Toolholders Z4.1
Wrench for spindle 10008, 15230
PRECI-FLEX® Adapter
Spindle cover see P99.1
Spindle sealing see P99.1
Coolant tubes 0.001.097

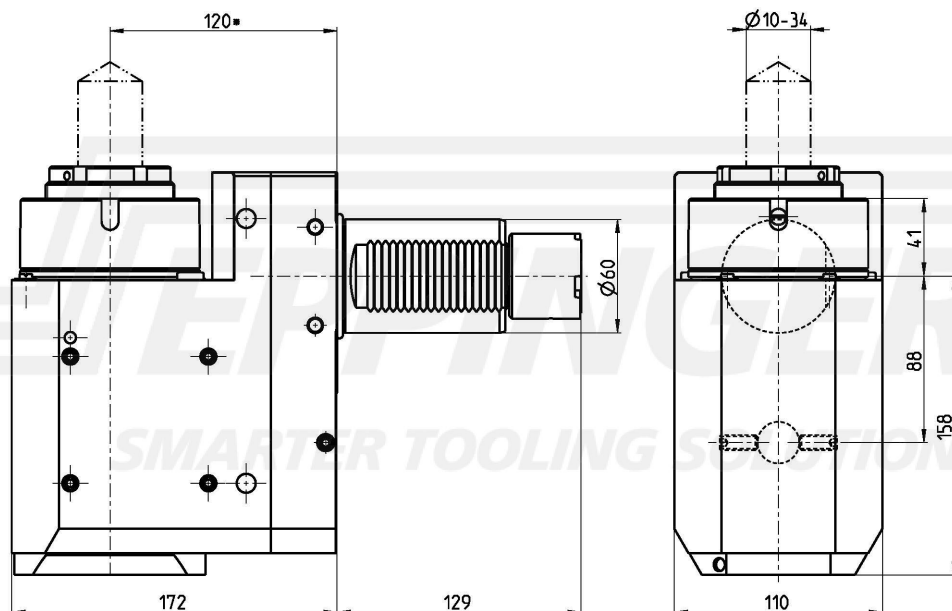

Technické údaje se mohou lišit

05.11.2007 | 17.09.2012