



Drilling and milling head, angular, left hand
collet chuck, ER25A, PRECI-FLEX®, external and central coolant
supply

číslo součásti 9.516.238

pro Hardinge Quest 6/42 + 8/51 + 10/65 (VDI30)

poměr 1:1
otáčky na vstupu max. 6000 1/min.
otáčky na výstupu max. 6000 1/min.
Krutící moment max. 40 Nm
Směr otáčení 
Rozsah dodání without wrench and collets
* Actual size inscribed on the tool

Příslušen. Collets see Equipment for Toolholders Z2.1
Sealing washers see Equipment for Toolholders Z4.1
Wrench for spindle 10006
PRECI-FLEX® Adapter
Spindle cover see P99.1
Spindle sealing see P99.1
Coolant tubes 218.844.220

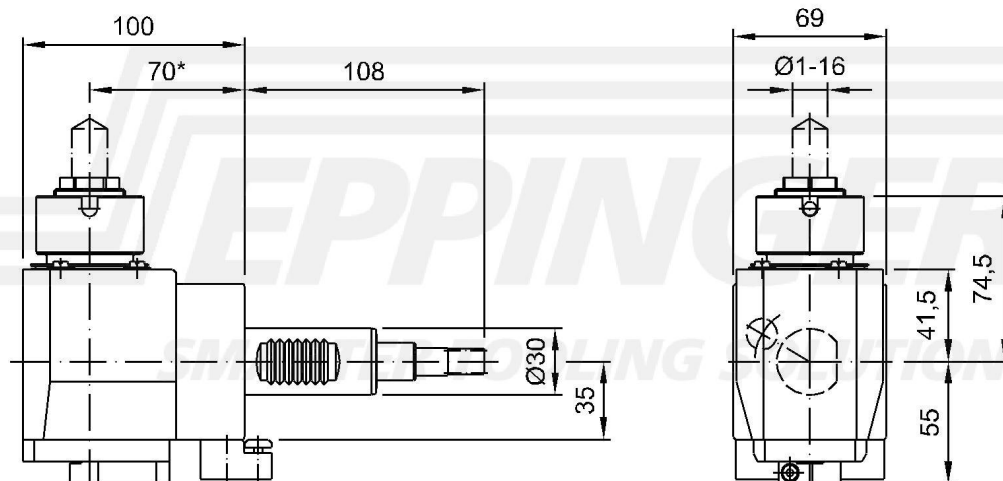

Technické údaje se mohou lišit

08.06.2006 | 17.09.2012

ESA Eppinger GmbH | Breitwiesenweg 2-8 | 73770 Denkendorf, Germany | www.eppinger.de