

Drilling and milling head, angular, right hand, short
collet chuck, ER25A, PRECI-FLEX®
external and central coolant supply



číslo součásti 9.503.329
pro HURCO TMM8i (VDI30) PIN55

poměr 1:1
otáčky na vstupu max. 6000 1/min.
otáčky na výstupu max. 6000 1/min.
Krouticí moment max. 40 Nm
Směr otáčení 
Rozsah dodání without wrench and collets
* Actual size inscribed on the tool



Příslušen. Collets see Equipment for Toolholders Z2.1
Sealing washers see Equipment for Toolholders Z4.1
Wrench for spindle 10006
PRECI-FLEX® Adapter
Spindle cover see P99.1
Spindle sealing see P99.1
Coolant tubes 0.000.377

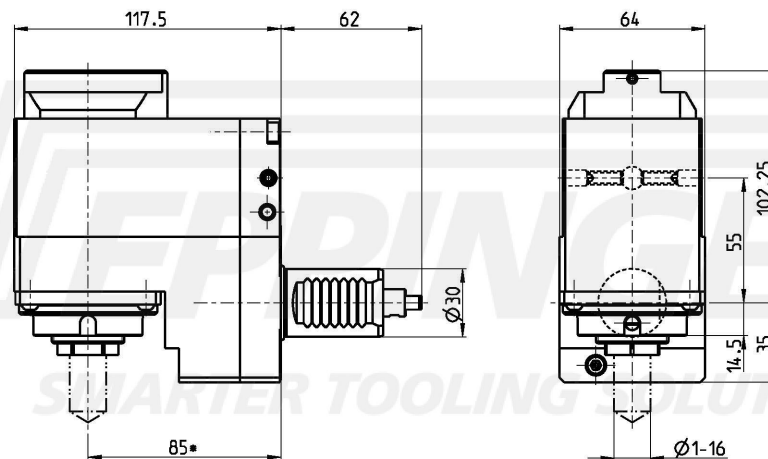

Technické údaje se můžou lišit

01.08.2016 | 01.08.2016