



Drilling and milling head, straight, short
collet chuck, ER50A, PRECI-FLEX®, external and central coolant
supply

číslo součásti 8.904.168
pro Duplomatic DIN 1809 (60)

poměr 1:1
otáčky na vstupu max. 4000 1/min.
otáčky na výstupu max. 4000 1/min.
Krouticí moment max. 200 Nm
Směr otáčení 
Rozsah dodání without wrench and collets

Příslušen. Collets see Equipment for Toolholders Z2.1
Sealing washers see Equipment for Toolholders Z4.1
Wrench for spindle 0.000.703, 10008
PRECI-FLEX® Adapter
Spindle cover see P99.1
Spindle sealing see P99.1
Coolant tubes 0.001.097

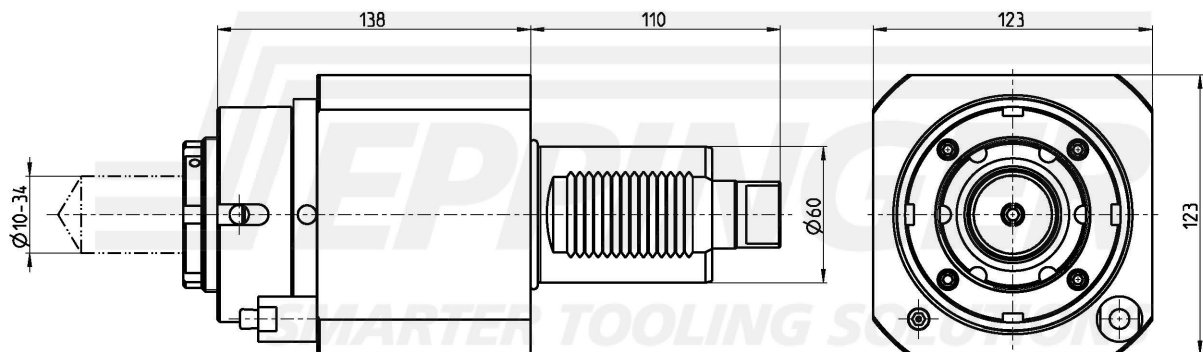
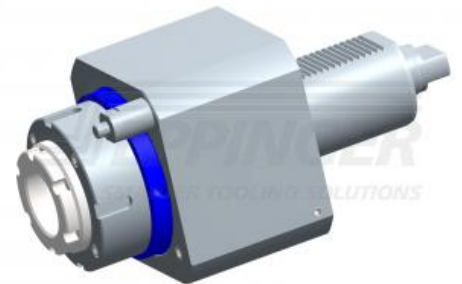

Technické údaje se můžou lišit

17.07.2007 | 12.09.2012