



Drilling and milling head, straight, short  
collet chuck, ER50A, PRECI-FLEX®, external and central coolant  
supply

číslo součásti 8.904.136  
pro Okuma LB/LU45-M

poměr 1:1  
otáčky na vstupu max. 4000 1/min.  
otáčky na výstupu max. 4000 1/min.  
Krouticí moment max. 200 Nm  
Směr otáčení   
Rozsah dodání without wrench and collets

Příslušen. Collets see Equipment for Toolholders Z2.1  
Sealing washers see Equipment for Toolholders Z4.1  
Wrench for spindle 0.000.703, 10008  
PRECI-FLEX® Adapter  
Spindle cover see P99.1  
Spindle sealing see P99.1  
Coolant tubes 0.001.097

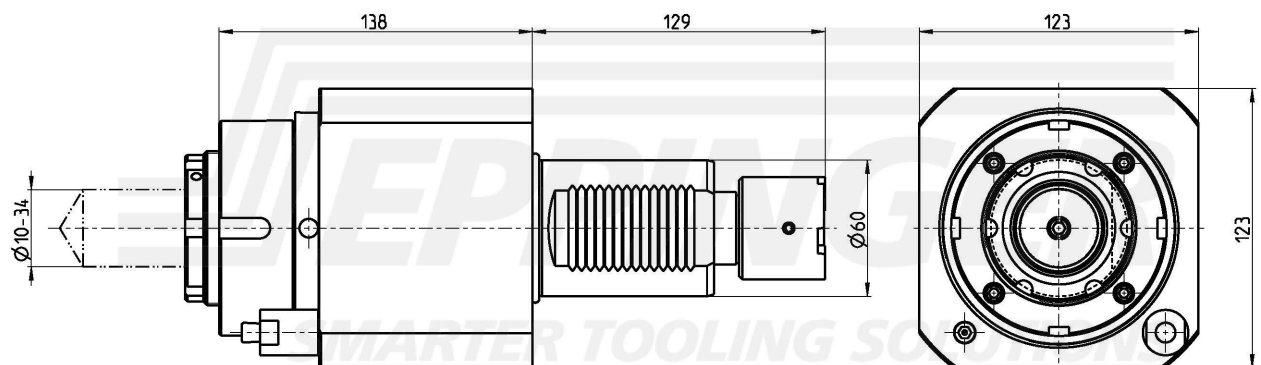
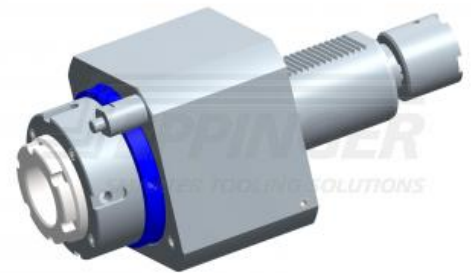

Technické údaje se mohou lišit

05.11.2007 | 17.09.2012