

Drilling and milling head, straight  
collet chuck, ER40A, PRECI-FLEX®  
external and central coolant supply



číslo součásti 8.822.301  
pro Okuma LU35-M

poměr 1:1  
otáčky na vstupu max. 4000 1/min.  
otáčky na výstupu max. 4000 1/min.  
Krouťicí moment max. 100 Nm  
Směr otáčení   
Rozsah dodání without wrench and collets

Příslušen. Collets see Equipment for Toolholders Z2.1  
Sealing washers see Equipment for Toolholders Z4.1  
Wrench for spindle 10006, 10009  
PRECI-FLEX® Adapter  
Spindle cover see P99.1  
Spindle sealing see P99.1  
Coolant tubes 218.460.220

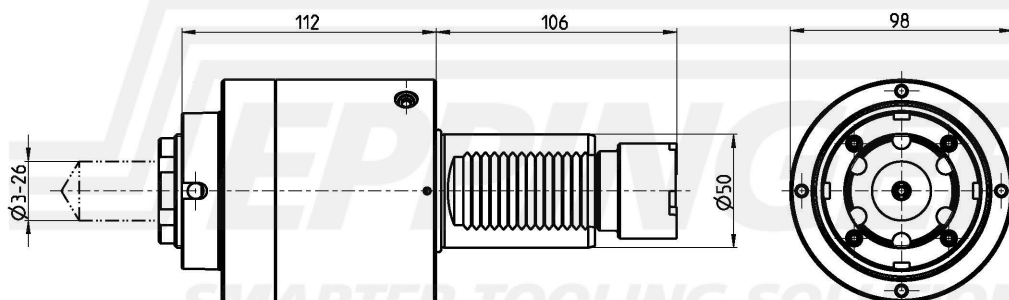

Technické údaje se můžou lišit

19.10.2005 | 10.03.2015

ESA Eppinger GmbH | Breitwiesenweg 2-8 | 73770 Denkendorf, Germany | www.eppinger.de