

Drilling and milling head, straight
collet chuck, ER40A, PRECI-FLEX®
external and central coolant supply



číslo součásti 8.822.294
pro EMAG VSC 300/400

poměr 1:1
otáčky na vstupu max. 4000 1/min.
otáčky na výstupu max. 4000 1/min.
Krutící moment max. 100 Nm
Směr otáčení 
Rozsah dodání without wrench and collets

Příslušen. Collets see Equipment for Toolholders Z2.1
Sealing washers see Equipment for Toolholders Z4.1
Wrench for spindle 10006, 10009
PRECI-FLEX® Adapter
Spindle cover see P99.1
Spindle sealing see P99.1
Coolant tubes 218.460.220

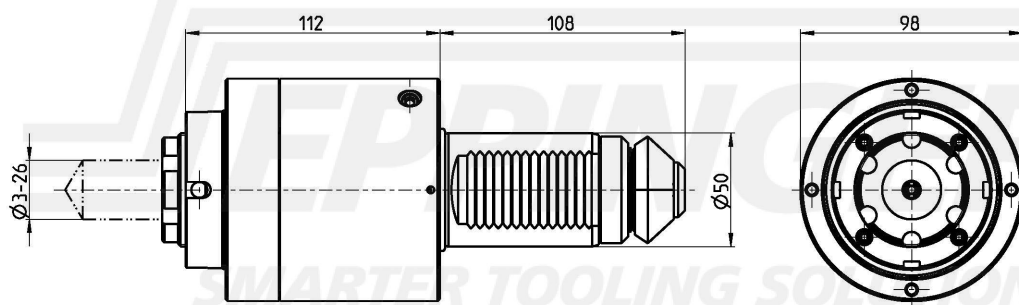

Technické údaje se můžou lišit

22.03.2005 | 12.09.2012

ESA Eppinger GmbH | Breitwiesenweg 2-8 | 73770 Denkendorf, Germany | www.eppinger.de