

Drilling and milling head, angular, double sided  
adjustable alignment pin  
collet chuck, ER32A, PRECI-FLEX®, external coolant supply



číslo součásti 7.172.430

pro Mazak Hyper Quadrex 100/150 MSY / HQR 200/250 (16 Stationen)

poměr 1:1  
otáčky na vstupu max. 6000 1/min.  
otáčky na výstupu max. 6000 1/min.  
Krouticí moment max. 70 Nm  
Rozsah dodání without wrench and collets  
\* Actual size inscribed on the tool

Příslušen. Collets see Equipment for Toolholders Z2.  
Wrench for spindle 10008, 0.000.468  
PRECI-FLEX® Adapter  
Spindle cover see P99.1

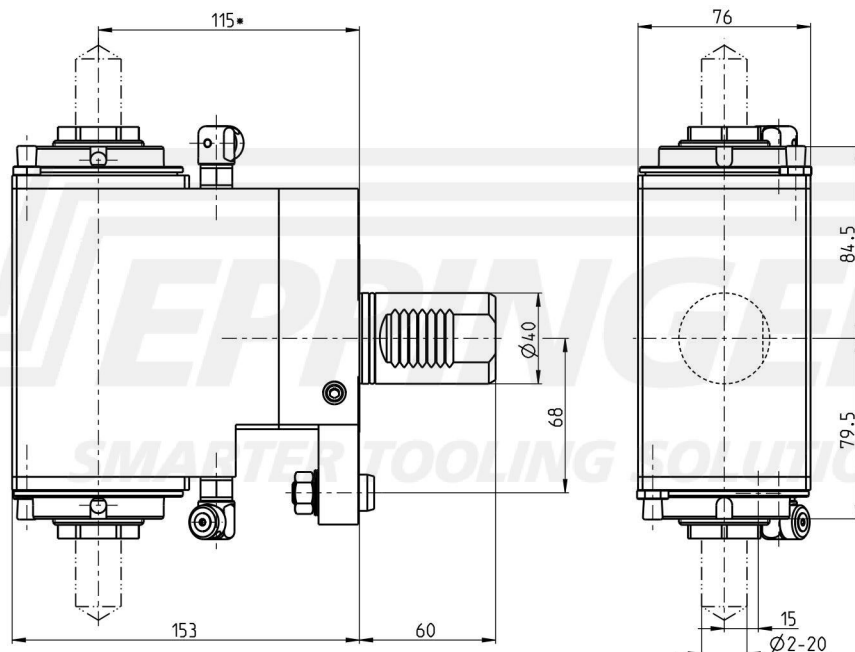

Technické údaje se můžou lišit

25.06.2018 | 25.06.2018