

SYSTEM 500

Nut- und Trennfräsen

groove milling
and slotting cutter

Typ 514

Fräswendeschnleidplatte,
für metrisches ISO-Gewinde,
Teilprofil, innen

indexable milling insert,
metric ISO-thread,
partial profile, internal

Steigung P = 1.5 - 6.0

pitch P = 1.5 - 6.0

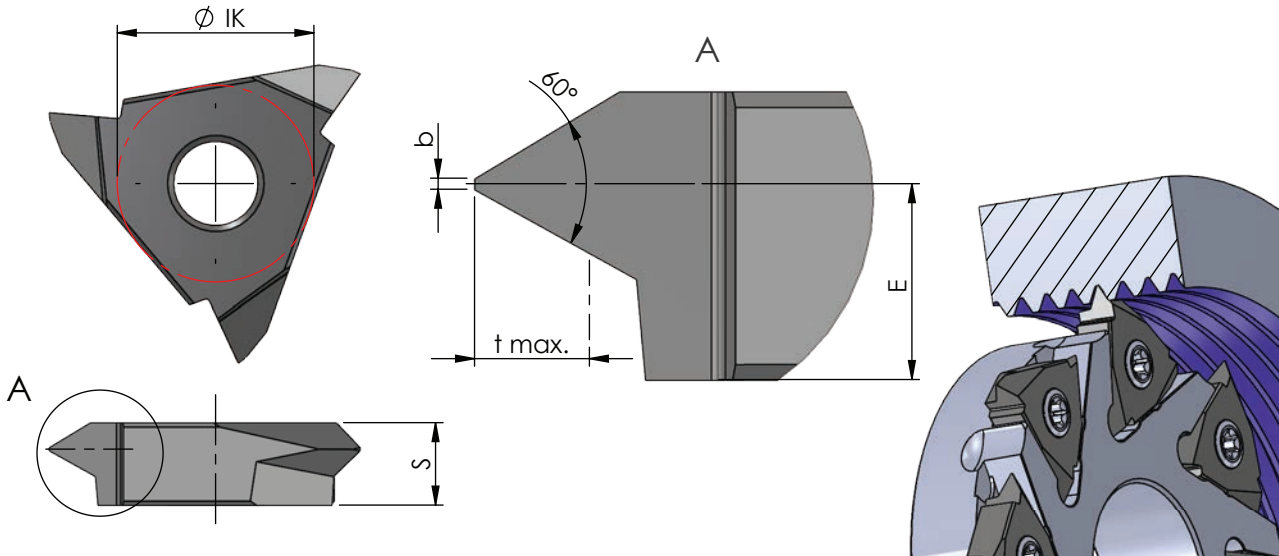

Abmessungen in mm

dimensions in mm

Bestellnummer part number	Steigung P pitch P	S	E	b	t max.	Ø IK -0.03	K10F	AL41F	P18C	für Fräseschaft / Messerkopf for milling shank / milling cutter
514.0815.01	1.5-1.5	5.4	4.60	0.19	0.81	13	●			
514.1020.01	2.0-2.0	5.4	4.40	0.25	1.08	13	●			
514.1535.01	1.5-3.5	5.4	3.90	0.18	1.89	13	●			
514.2140.01	3.5-4.0	5.4	3.70	0.43	2.17	13	●			500...
514.2445.01	3.75-4.5	5.4	3.40	0.47	2.44	13	●			510...
514.2750.01	4.0-5.0	5.4	3.35	0.50	2.70	13	●			581...
514.3260.01	4.5-6.0	5.4	3.00	0.56	3.25	13	●			
514.4060.01	3.5-6.0	5.4	3.00	0.44	3.52	13	●			

Weitere HM Sorten können Sie in der Sortenübersicht im Kapitel "Technische Hinweise" und der Preisliste finden.

Bestellbeispiel:
für Sorte AL41F:
514.0815.01/AL41F

More carbide grades you can find in the grades summary in the chapter "technical instructions" and in the price list.

order-example:
grade AL41F:
514.0815.01/AL41F