

SYSTEM 500

Nut- und Trennfräsen

groove milling
and slotting cutter

Typ 500.44.3

Frälerschaft

D min. 45 mm
t max. 4.0

milling shank

D min. 45 mm
t max. 4.0

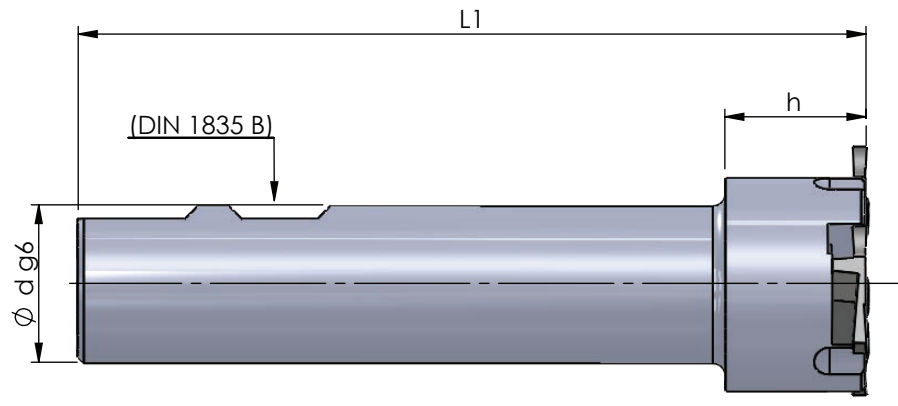
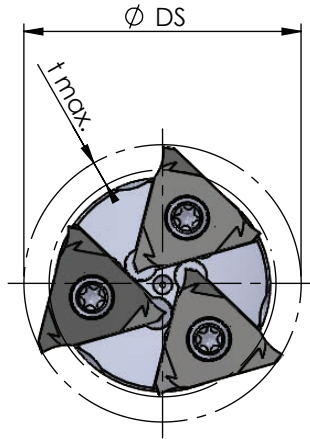

Abmessungen in mm

dimensions in mm

Bestellnummer part number	Ø DS	Ø d g6	t max.	L1	h	Schneidenzahl number of cutting edges	Spannschraube screw	Schraubenschlüssel wrench	Anzugs- drehmoment torque	für Schneidplatten for insert
500.44.3	44	25	4	125	22.4	3	85.818	TX-20/80	3.0 Nm	514....

Achtung:
Frälerschaft ist ohne Schneidplatten!

attention:
Milling shank is without inserts!

Bestellbeispiel:
500.44.3

order-example:
500.44.3