



Horizontal Moving Quick Vise



2 WAY MOVING

- Special design, for milling M/C, drilling M/C.
- Easy & quick to find process position.
- For round table drilling machine. If it don't have cross table.
- 360° rotation

NEW

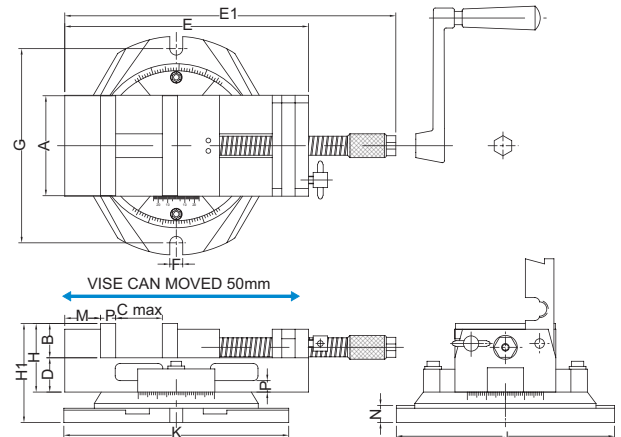
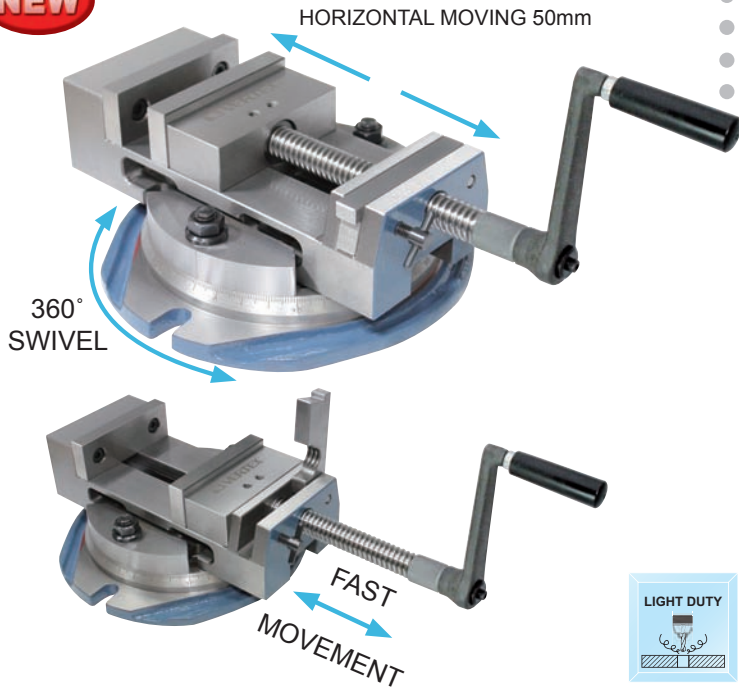

LIGHT DUTY	FAST MOVE	ACCURACY GUARANTEE 0.01/100 MM 0.02/50	TABLE HARDNESS	BENDING PROOF	MECHANICAL	patent PAT.
------------	-----------	---	----------------	---------------	------------	-----------------------

ORDER NO.	A	B	C max.	D	E	E1	F	G	H	H1	J	K	M	N	P	MAX.Clamp Force kgf	G.W.	CODE NO.
VQW-80	81	34	85	36	230	374	14	214	70	100	242	230	28	30	12	700	13.5	1002-245
VQW-100	105	36	104	36	256	422	16	264	72	106	303	272	37	34	16	800	15.8	1002-246
VQW-130	131	36	125	38	297	490	16	264	74	108	303	272	38	34	29	800	22.7	1002-247



Quick Setting Vise

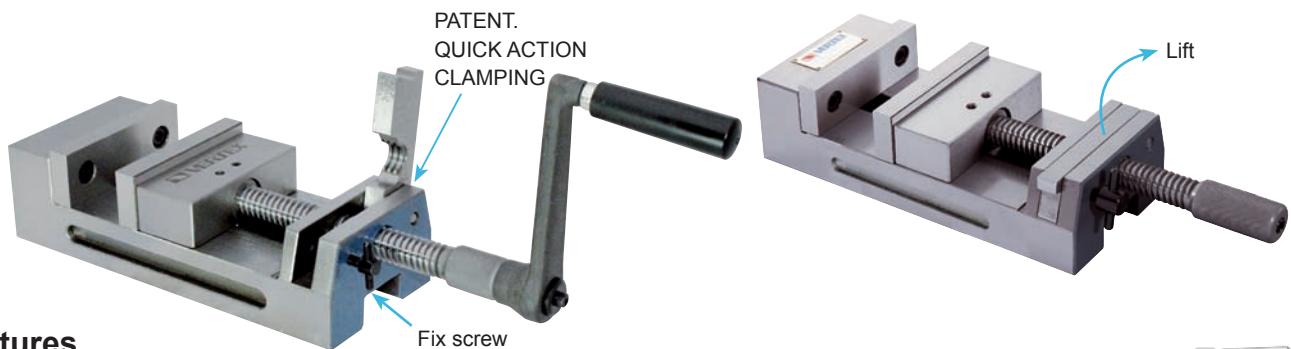

Features

- Special design for quick clamping. (From the acme thread shaft stationly)
- Quick setting by sliding movement. Big clamping capability.
- Operating very quick and easy, can increase so much working efficiency than you can image.
- Good for short term and massive production or proto type work.
- Suit for milling machine, grinder machine, precision drilling machine using.
- Accurate grounded and assembled.
- Precision cut acme thread, it can get 800kgs high clamping force.
- Horizontal & vertical
- Accuracy 0.02 / 100 mm

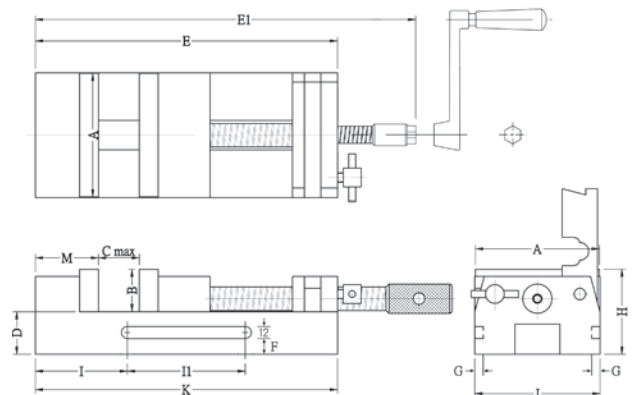
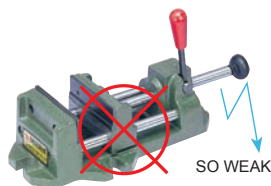

LIGHT DUTY	FAST MOVE	ACCURACY GUARANTEE 0.01/100 MM 0.02/50	TABLE HARDNESS	BENDING PROOF	MECHANICAL	patent PAT.
------------	-----------	---	----------------	---------------	------------	-----------------------

ORDER NO.	A	B	C max.	D	E	E1	F	G	H	I	I1	J	K	M	MAX.Clamp Force kgf	G.W.	CODE NO.
VQS-3	81	34	85	36	230	374	12	5	70	51	128	82	230	50	700	7	1002-262
VQS-4	105	36	104	36	256	422	12	5	72	54	148	106	256	54	800	9.5	1002-263
VQS-5	131	36	125	38	297	490	13	5	74	59	178	132	297	67	800	14.5	1002-264