

- It's a practical piece of equipment with excellent precision and a high quality finished.
- Body, movable jaw and swivel base made of closes-grained high tensile iron castings. Built for machining and retained accuracy.
- Jaw plates were made of hardened and grounded tool steel.
- It's the most suitable for the Milling, Grinding and Drilling.
- ACCURACY WITHIN 0.02mm
- In order to ensure the accuracy when using it' better that don't put swivel base together.



Order No. & Dimensions

ORDER NO.	A	B	C OPEN	D	E	E1	F	G	H	I	J	K	L	M	Max. Clamp Force (kgf)	G.W. (kgs)	C.F.T. (cm)	CODE NO.
VK-4	104	36	62	76	293	310	13	145	83	113	176	122	15	65	900	10	33x13x13	1002-040
VK-5	132	37	80	92	362	384	13	172	97	129	209	147	15	84	900	16	40x16x15	1002.041
VK-6	154	43	112	105	442	473	15	209	108	148	260	181	16.5	90	1000	27	51x22x19	1002-042
VK-8	204	63	146	127	579	609	18	312	148	190	350	234	21	122	1400	59	65x27x25	1002-043

Super Open Vise

MECHANICAL TYPE



VJ-600

EXCEPT THE HYDRAULIC SYSTEM, THE FEATURE IS SAME AS VH-TYPE ACCURACY WITHIN 0.02mm

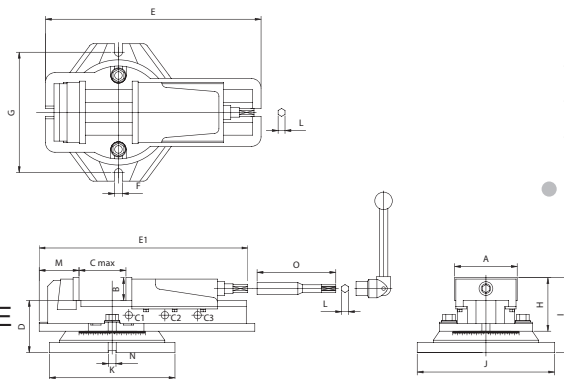

VJ-400 JAW OPENED 185mm
 VJ-500 JAW OPENED 245mm
 VJ-600 JAW OPENED 305mm

- In order to ensure the accuracy when using it' better that don't put swivel base together



Order No. & Dimensions

ORDER NO.	A	B	C max	Opening Size For Capacity			D	E	E1	F	G	H	I	J	K	L	M	N	O	Max. Clamp Force (kgf)	G.W. (kgs)	CFT (cm)	CODE NO.
				C1	C2	C3																	
VJ-400	110	38	185	0-65	52-129	116-185	97	386	516	15	240	96	135	270	238	14.5	90	16	156	1500	25	46x26x16	1002-050
VJ-500	132	48	245	0-78	70-158	150-245	110	455	580	17	255	113	158	290	265	19	85	16	166	1500	34	48x28x18	1002-051
VJ-600	154	56	305	0-111	97-211	197-305	118	546	722	17	255	131	175	290	265	19	111	16	200	1500	46	57x30x22	1002-052